

R2118

standard back

The R2118 standard back offers, low cost, utility seating for vehicle conversions where the legal requirement for lap and diagonal seat belts does not apply.

A range of seat widths, leg heights and accessories is available.

Features

- Available with retractor or static lap-belts
- Available as singles, doubles or trebles
- Available in three widths (400, 425, 450mm)
- Variable leg heights and centres
- Lap belts compliant to Community Directive 76/115/EEC (as amended)
- Static or retractor lap belts can be fitted to in-built anchorage points.

Lap belt anchorage points comply with 76/115/EEC (as amended) for category M2 and M3 vehicles.

NB: Lap/diagonal belts are NOT available on this product (see *Defender* range)



Dimensions (for guidance only)

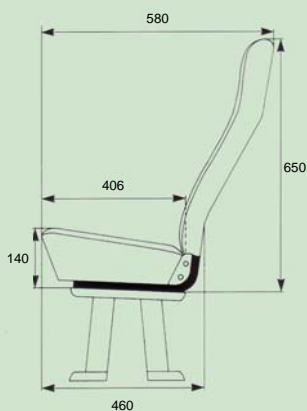

Trim

To match original material in most vehicles. Vinyls and moquettes also available.

Accessories

- Armrests
- Headrests
- Quick-release fittings

Notes

1 Caution: It is not possible to test every permutation of seat width, accessory combination, leg height, position and type, or seat belt requirement. For this reason, it must be emphasised that compliance cannot be assumed where there is any deviation from the standard supply or assembly method. Additionally, the advantages of this product may be lost if insufficient consideration is given to the method of installation of the seat in the vehicle.

2 FULL compliance to seat belt anchorage regulations can only be achieved through vehicle testing.

3 Product improvement may affect specifications.

RESCROFT
OutSTANDING InSEATING

VEHICLE SEATING - DESIGN AND MANUFACTURE

Rescroft Limited

20 Oxleasow Road, East Moons Moat,
REDDITCH, Worcestershire, B98 0RE, UK.

Tel: +44 (0) 1527 521300

Fax: +44 (0) 1527 521301

Email: enquiries@rescroft.com