

# R2180

## tip-up

The R2180 tip-up seat provides low cost, compact, occasional seating.

Installed rear-facing, it is available in a variety of forms and will, optionally, accept armrests and static lap-belts.

### Features

- Designed for rear-facing installation
- Available as 400mm single unit only
- Available with floor-fixing frame
- Spring-assisted folding mechanism

### Accessories

- Static lap belts
- Armrest
- Gas-strut folding system

### Trim

To match original material in most vehicles.  
Vinyls and moquettes also available.



Dimensions (for guidance only)

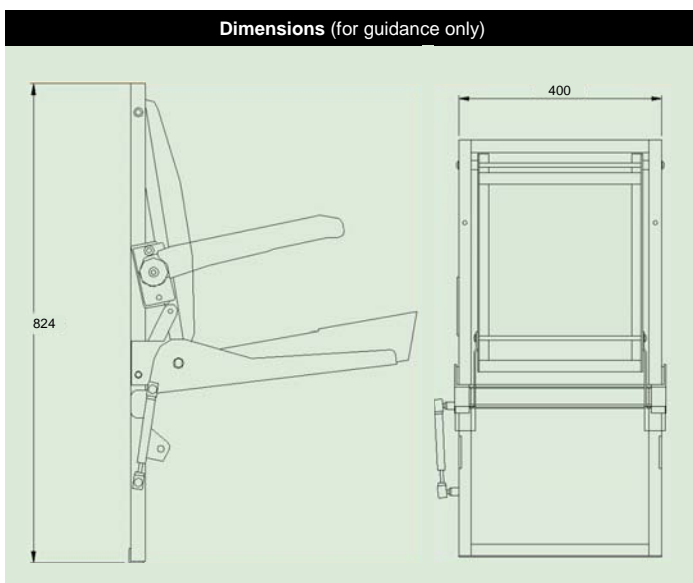

### Notes

1 Caution: It is not possible to test every permutation of seat width, accessory combination, leg height, position and type, or seat belt requirement. For this reason, it must be emphasised that compliance cannot be assumed where there is any deviation from the standard supply or assembly method. Additionally, the advantages of this product may be lost if insufficient consideration is given to the method of installation of the seat in the vehicle.

2 FULL compliance to seat belt anchorage regulations can only be achieved through vehicle testing.

3 Product improvement may affect specifications.

**RESCROFT**  
OutSTANDING InSEATING

VEHICLE SEATING - DESIGN AND MANUFACTURE

**Rescroft Limited**

20 Oxleasow Road, East Moons Moat,  
REDDITCH, Worcestershire, B98 0RE, UK.

Tel: +44 (0) 1527 521300

Fax: +44 (0) 1527 521301

Email: [enquiries@rescroft.com](mailto:enquiries@rescroft.com)