



Plica™

folding semi-high back

For vehicle operators, lifting removable, M1 seating into, and out of, vehicles is strenuous and time-consuming. The Plica folding seat is designed to assist in both areas by providing a fold-away facility that eliminates the need to remove the seat at all.

Compact and realistically priced, the Plica can be fitted along the full length of the vehicle, simply folding against the side when not in use providing maximum aisle width for wheelchair users. Passengers are seated facing forwards and the seat has been tested and approved to M1 standards.

Features

- M1 tested seat belt anchorages
- Forward facing when seated
- Fitted with inertia reel lap and diagonal seat belt
- 200mm deep when folded
- Compliant on Embus floor system
- Compliant to Reg14 and Reg 80 for category M2/M3 applications [Type Approval No. 00870000-80R]

General

Available in different heights to suit most vehicles. Supplied as single units: left or right-hand applications.

Trim

To match original material in most vehicles. Vinyls and moquettes also available.



Dimensions (for guidance only)

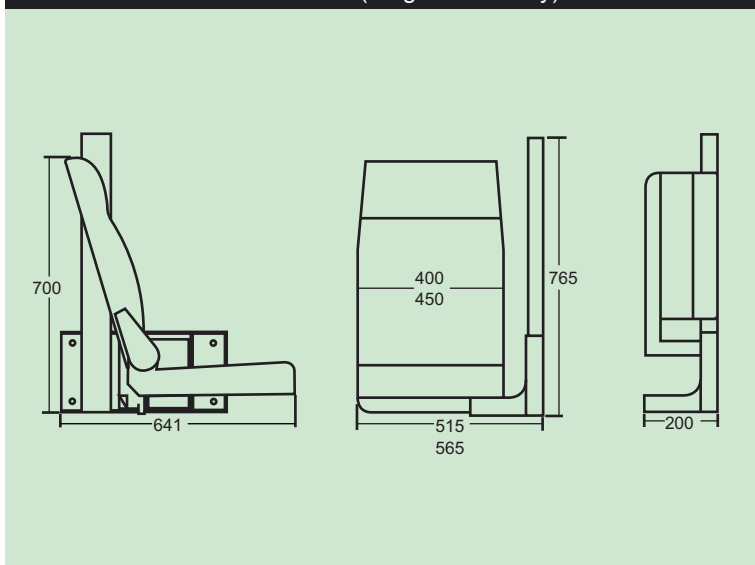

Notes

1 Caution: It is not possible to test every permutation of seat width, accessory combination, leg height, position and type, or seat belt requirement. For this reason, it must be emphasised that compliance cannot be assumed where there is any deviation from the standard supply or assembly method. Additionally, the advantages of this product may be lost if insufficient consideration is given to the method of installation of the seat in the vehicle.

2 FULL compliance to seat belt anchorage regulations can only be achieved through vehicle testing.

3 Product improvement may affect specifications.

Accessories

- Aisle-side arm rest
- Headrests (adjustable and removable)

RESCROFT™
OutSTANDING InSEATING

VEHICLE SEATING - DESIGN AND MANUFACTURE

Rescroft Limited

20 Oxleasow Road
REDDITCH, B98 0RE, UK.

T: +44 (0) 1527 521300

F: +44 (0) 1527 521301

@: sales@rescroft.com

W: www.rescroft.com