



Defender III™

semi-high back

Rescroft's flagship product, Defender III continues the Defender tradition of stylish, comfortable, ultra-safe M1/M2/M3 passenger seating.

It remains the most popular semi-high back choice for most bodybuilders and vehicle operators. For M2 and M3 applications, the seat is available as single, double and treble units: for M1 applications, as singles and doubles.⁽⁵⁾

Features

- Minimised seat pitch measurement
- Compliant on Embus floor system
- Standard lap/diagonal, height adjustable, inertia reel belt - fully integrated
- Compliant on various quick-release fittings
- Variable leg centres
- Full range of accessories
- Compliant to Community Directive 76/115/EEC (as amended) for category M1, M2 and M3 applications
- Textured paint finish
- Choice of leg rake
- Choice of belt types (including Body Loc)
- Optional ABS back
- Optional flexible seat belt buckle
- Optional twin-belt, retractable harness system, with height adjustment
- Optional coloured webbing on specific seat belts
- Optional ISOfix connection



Accessories

- Armrests
- Grab handles
- Headrests (adjustable)

Trim

To match original material in most vehicles. Vinyls and moquettes also available.

Bases

All seats are supplied with legs (height and quantity according to application). Braced bases are available for use with quick-release fittings.

RESCROFT™
OutSTANDING InSEATING

VEHICLE SEATING - DESIGN AND MANUFACTURE Rescroft Limited

20 Oxleasow Road, East Moons Moat,
REDDITCH, Worcestershire, B98 0RE, UK.
+44 (0) 1527 521300
sales@rescroft.com
www.rescroft.com

Dimensions (for guidance only)

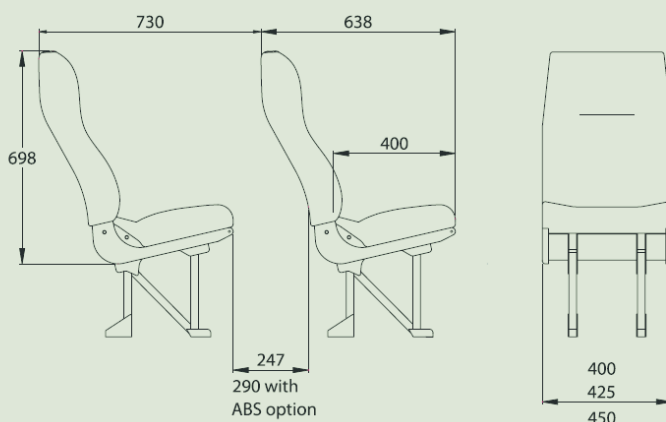

Notes

- 1 Caution: It is not possible to test every permutation of seat width, accessory combination, leg height, position and type, or seat belt requirement. For this reason, it must be emphasised that compliance cannot be assumed where there is any deviation from the standard supply or assembly method. Additionally, the advantages of this product may be lost if insufficient consideration is given to the method of installation of the seat in the vehicle.
- 2 FULL compliance to seat belt anchorage regulations can only be achieved through vehicle testing.
- 3 Product improvement may affect specifications.
- 4 Leg height restrictions may apply.
- 5 M1 double only available using 3 heavy-duty legs.