

Defender III Accent

fold-up
semi-high back

In 1998, an amendment to UK regulations introduced the requirement for rear-facing seating to be tested to the minimum loading for M3 category vehicles. The Defender III Accent has achieved this standard and has been designed to exactly complement Rescroft's range of fixed-cushion Defender seating.

When installed rear-facing, this product is suitable for use in M1 category vehicles.

Features

- Fold-up cushion
- Tested and approved for M3 category vehicles (single-leg version) or M2 (two-leg version)
- Fully integrated seat belt reels
- Height adjustable lap/diagonal inertia-reel belts as standard
- Available in three widths (400, 425, 450mm)
- 330mm fixing hole centres
- Leg centres (front to back) to suit quick-release fittings
- Compliant on Embus floor system
- Compliant to Community Directive 76/115/EEC (as amended)
- Optional armrests, adjustable headrests and quick-release fittings
- Trim to match original material in most vehicles. Vinyls and moquettes also available



Dimensions (for guidance only)

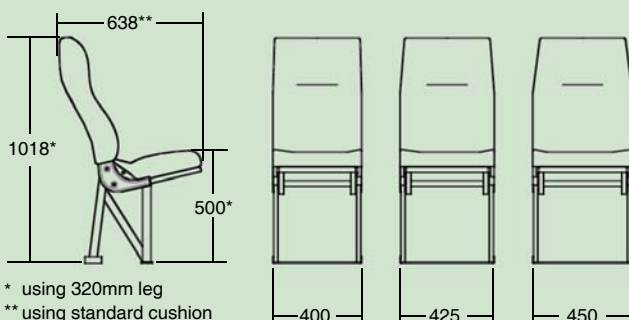

Notes

1 Caution: It is not possible to test every permutation of seat width, accessory combination, leg height, position and type, or seat belt requirement. For this reason, it must be emphasised that compliance cannot be assumed where there is any deviation from the standard supply or assembly method. Additionally, the advantages of this product may be lost if insufficient consideration is given to the method of installation of the seat in the vehicle.

2 FULL compliance to seat belt anchorage regulations can only be achieved through vehicle testing.

3 Product improvement may affect specifications.

RESCROFT

OutSTANDING InSEATING

VEHICLE SEATING - DESIGN AND MANUFACTURE

Rescroft Limited

20 Oxleasow Road, East MoonsMoat,
REDDITCH, Worcestershire, B98 0RE, UK.

Tel: +44 (0) 1527 521300

Fax: +44 (0) 1527 521301

Email: enquiries@rescroft.com